

INSTALLER'S INSTRUCTIONS FOR TRI-METRIC™

Battery system monitor, Model TM-2025-RV

revised March 14, 2009

IMPORTANT: The wiring installation for this meter, especially the shunt installation must be performed by someone knowledgeable on proper wiring, electrical practices, and safety. If you do not have this knowledge please have someone install it who does, or at least get some competent help to supervise the installation.

To install:

1. Please read or scan two pages of introductory information in section A.
2. Consult drawings Figure 1 and 2 (pages 7-8).
3. Follow step by step installation instructions in section B.
4. Install at least 3 important numbers into meter as described in section C.

Contents

- A. Meter Installation: Preliminary:** What you need to know before installing the TriMetric meter.
- B. Meter and Shunt Installation:** How to make connections from meter to battery and shunt.
- C1. Entering required three setpoints in TriMetric memory:** How to enter necessary data related to your battery system to make the TriMetric displays give you the correct information.
- C2. Information on the next (optional) three program setpoints.**

Limited warranty. Meter is warranted for 1 year against any manufacturing defects. Any meter not meeting the specification or performance description will be replaced or repaired within one year of purchase, provided it has not been subject to abuse or misapplication, and provided the defective unit is shipped to us if we request it. Contact your dealer or us before shipping.

BOGART ENGINEERING

19020 Two Bar Road

Boulder Creek, CA 95006

(831) 338-0616

www.bogartengineering.com

A: METER INSTALLATION--PRELIMINARY: Useful information to review before installing.

Choosing meter location and some benefits of battery monitoring: To make best use of this monitor, we recommend that it be located where it can be readily observed in the living area where the electrical power is used, such as a kitchen or living room. It displays the current draw or the charging current by either "amps" and "watts". (It is designed to be located up to a few hundred feet away from the battery bank using 4 wires.) One important use is to learn how much electrical power various appliances draw by looking at the "amps" or "watts" readout first with the appliance off, and then observing how much the current increases when you turn it on. This is inconvenient if the meter is located away from the living area. After a while you will become instinctively familiar with the electrical usage of your appliances, so you won't need to refer to the meter. Also, you can become familiar with "normal" electrical usage, and occasionally check that it is not excessive, which would indicate some appliance has been unknowingly left on. Using the "BATTERY % FULL" display, (or "Amp-hours from full") readout you will be able to see approximately how much energy you've withdrawn from the battery bank. If you have "lead acid" batteries--the most commonly used type--the "Volts" readout gives useful information about the "extreme" cases, when your batteries have gotten a nearly full charge, (which, while *charging* a 12 volt lead-acid battery will typically show voltage above 14.3 volts) or on the other hand when they are in a low charge state (which, while *discharging* a 12 volt lead acid battery will typically show voltage 10.8 to 11.6 volts depending on how many "amps" are being withdrawn). However "volts" is not too informative when the batteries are between 20%-90% charged, since in this case exact voltage depends on several factors, including: *whether* the batteries are being charged or discharged, *how fast* they are being charged or discharged, temperature of the battery, and the recent past history of charge/discharge. For example, if they are charged at a high rate for awhile, the voltage will rise higher than they would be after charging stops, due to what are called "polarization" effects. The TriMetric, therefore, uses the battery voltage as an indicator for when the batteries are "charged". Then--when discharging the batteries from there, the "BATTERY % FULL" (or "amp-hours from full") reading is a better guide for determining intermediate battery state of charge. Voltage can again be useful for seeing that the batteries are in a state of near discharge--this is useful since it is not good for lead-acid batteries to be too often, or remain too long nearly discharged. (Multiply voltages above by 2 for 24 volt systems or 4 for 48 volt systems)

The TM-2025 can measure two battery systems if you choose: This meter measures one battery system comprehensively, including *volts* and battery charging/discharging *amps*, typically for the one that supplies power to appliances so you can measure accurately the *state of charge* (how much energy is in the batteries.) In addition, it will monitor *voltage only* on a second battery having a common negative connection, which could be the engine starting battery.

Permissible battery voltage: This meter is suitable for battery systems with nominal voltage from 8 to 65 volts. *It should not be connected to systems which will ever exceed 65 volts.*

You may choose three different operating levels from simplest to more complex: It comes initially programmed at the lowest Operating Level: L1 which will furnish the most important data. There are also levels "L2" or "L3" which add more functionality, but with more complexity you will need to read more of the operating instructions.. If you are new to this, begin with L1, and after becoming familiar with the meter you may easily advance to L2 or L3 at any time should you need to. These levels are described in the TriMetric User's Instructions.

Lightning considerations: The meter has been designed with reasonably good protection against lightning.

SHUNT AND WIRING CONSIDERATIONS

A shunt (a very low resistance, accurate, high power resistor) must be wired into your battery system as described in section B of these instructions. This is how current (amps) and watts are measured by this meter: The "amps" shown on the meter measures whatever current passes through this shunt. Therefore the shunt must be wired in series with the wire which carries the current to be measured. **The shunt is almost always installed between the negative terminal of the battery to all loads and charging sources** (as shown in the wiring diagram on page 15.) It is located near the batteries, since the high current carrying wires must be kept short. The TriMetric measures the current ("amps") by measuring the very small voltage drop across this shunt. Watts measured by the meter are shown by multiplying the "volts" times the "amps".

Shunt requirements: There are two choices of shunts which may be used: Most systems will use the 500 amp-50 mV shunt. For smaller systems you can use a 100A/100mV shunt (For this choice the meter must be programmed at Operating Level L3.)

Who might want to use the 100A/100mV shunt? (requires Operational Level L3) If you have an unusually small system that uses less than 70 amps maximum (charging or discharging) this shunt will show an extra digit to the right of the decimal point, and resolve currents as low as 1/100 amp. But the 100A/100mV shunt can get too hot with a typical 12V system with a 1000 watt inverter.

Technical note: Incidentally, it is only the shunt *ratio* between amps to mV, which is important to the meter--so, for example, a 200 amp-200 mV. shunt can, from the meter's point of view, be considered equivalent to the 100 amp-100 mV shunt. The

implication, when a shunt is rated at "100 amps-100 mV." is that it may safely carry *up to* 100 amps maximum--however unfortunately in many cases so-called "100 amp" shunts will not carry this much without overheating--especially some of the "mini" shunts of this type. For more information, request : "Information on Shunts" from Bogart Engineering, or get it from the internet address shown on page 1.

If it is desired to measure *only* total solar input current, or only total load current (and amp-hours): you must wire the shunt such that only the solar current, or load current will pass through the shunt. The "Battery % Full" display will be meaningless in this case. In this case it would be advisable to use Operating Level L3 which will enable you to turn off the "automatic reset" of amp hours.

Maximum cable length for "G1" wire from meter to shunt for the following wire sizes are: #26 gauge: 45 feet. #24 gauge: 70 feet. #22 gauge: 100 feet. #20 gauge: 180 feet. #18 gauge: 300 feet. #16 gauge: 400 feet.

If the distance between battery and meter is more than 100 ft (30 meters) you may need to increase the size of the "G1" wire or possibly "+" wire: Use wire with resistance less than 2 ohms total for the G1 wire. The G2 and SIG wires can each be over ten times higher than this with no problem. If the single wire connecting from the meter + and M+ terminals to the battery is over 2 ohms, the "volts" will read slightly less than true. (If the wire is less than 2 ohm, the meter "volts" error will be less than 0.06 volts--almost negligible). However, wires of *ten times* this resistance may be used with no "volts" error if a separate (additional) wire is run for the M+ terminal: Disconnect the short wire between the + and M+ terminals at the meter terminal block, and connect two *separate* (long) wires to the fuse at the battery + terminal--and run one of these to the + terminal of the meter, and the other to M+ terminal.

Meter to shunt cable requirements: The meter may be located up to hundreds of feet away from the shunt if desired, in an indoor location, with four or five power and control wires connecting between the shunt and the meter. (These 5 wires are labeled on the connector on the circuit board inside the TriMetric: "G1", "G2", "SIG" and "+B1" and "+B2".) The meter can be connected to the shunt with 5 wires, or a cable with 5 conductors. If only one battery system is being measured only 4 wires are required.. It would be advisable to use twisted pair wires in the cable if any other power wires are being run near and parallel with these, however it should not be necessary otherwise. If twisted pair wire is used, it should be connected as shown in the drawing. The simplest way to connect the meter is to use wire size large enough, as shown by the following:

TriMetric maximum current capability: The TriMetric will measure current properly up to 999 amps with the 500 A-50 mv shunt. With the 100 A-100 mv shunt the meter measurements will be OK up to 300 amps. However, **at these currents the shunt is going to get too hot:** the 100 A shunt as described will be producing the heat of a 90 watt light bulb, and the 500 A shunt will produce heat equivalent to a 100 watt light bulb. (The heat produced by the shunt will be proportional to the **square** of the current passing through it, so each time the current is doubled the heat increases by a factor of 4.)

Serial data output is available that outputs all real time data. Another data access method for techies.

Mounting the meter: TM-2025 RV model comes in a white, surface mount box (3 x 4-1/4 x 1-1/4 inch deep). It can be mounted to a wall with screws at the top and bottom flanges.

B. METER and SHUNT INSTALLATION Even momentarily connecting "+" wire from battery to meter incorrectly or backwards will destroy it. Carefully following these steps will minimize that possibility.

- IMPORTANT:** A qualified person familiar with safe electrical practices and the local electrical code should install this meter--particularly when installing the shunt. Accidentally shorting the battery with a tool or other metal such as a finger ring can result in severe burns from an arc (think "arc welder"). Obviously, mistakes in wiring could seriously damage your electrical system.
- Refer to wiring drawing on last page--please read all notes.
- To prevent damage to meter, do not install into a battery system that has a voltage that will rise above 65 volts. It is designed for a maximum "nominal" 48 volt battery system.
- A (2Amp, fast-blow) fuse shown located *near the battery* in the wiring diagram is for safety. If not provided with your meter, such "in line" fuses are available at Radio Shack.

To install meter and shunt you will need:

- One shunt (usually 500A/50mV size)
- A length of cable containing 4 or 5 wires long enough to connect from battery system to meter. Or 4 or 5 individual wires may be used. (Five wires if two batteries are being measured.) The wire used for the + connection of the battery should have a 2A fuse at the battery end to protect the wire in case of a short. This shows minimum size wire for distances shown:
#26 gauge: 45 feet. #24 gauge: 70 feet. #22 gauge: 110 feet. #20 gauge: 180 feet. #18 gauge: 300 feet. #16 gauge: 400 feet. (These represent distances for approximately 2 ohm wire resistance.)
- A short length of cable with large bolt eyelets on each end to connect one end of shunt to negative battery terminal: of same or larger size (diameter) than the large cable that connects to the + and – terminals of the battery.
- Suitable wrench or tools for connecting the large cables to battery and shunt
- Very small screwdriver for connecting wires to meter terminal block
- Small Phillips screwdriver for removing front panel of meter
- Medium screwdriver for connecting wires to shunt
- A drill for putting a small hole to permit cable to enter the meter box

STEP 1: Install shunt: Turn off main breaker to battery. Refer to diagram Figure 1 and Figure 2 for details. You'll need an additional short length of cable at least as large (in diameter) as the largest cable going to the negative battery connection. It should have bolt lugs at each end to connect from the negative battery terminal to one side of the shunt. The battery cable size must be large enough to accommodate the maximum system charging or discharge amps from the battery.

	CONNECTION	WIRE COLOR
<div style="border: 1px solid black; padding: 5px; display: inline-block;"> TWISTED PAIR (IF USED) </div> 	G1	
	G2	
	SIG	
	+B1	
	+B2	

STEP 2 Making connections from meter to battery and shunt: We suggest a cable with different colored wires to reduce the probability of wiring errors. The chart above has a place for you to write the colors for each wire. The cable wires at the TriMetric end of the cable must connect to a terminal block located on the green circuit board in the TriMetric. If cable with twisted pair wires are used (not normally needed), the wires labeled “G2” and “SIG” should be run with one twisted pair, and if another pair is used, “G1” and “+B1” may be run an another pair, although twisted pair here will not give any benefit. If it is desired to measure the “volts” of a second battery, you may run a fifth wire to its positive terminal. The terminal block on the circuit board accommodates wire size from 16 to 26 AWG.

If twisted pair wires in a cable are used, (which is not necessary unless other power wires run near these wires) clearly establish which wires in the cable are “paired” together. This often requires stripping quite a bit of insulation to see which pairs are twisted together. Then choose one twisted pair for G2 and SIG (the ones for which twisted pair is most helpful), and record the wire colors for that pair below in the chart. You may want to use a piece of tape at each end of the cable to tie these two together, to clearly mark the pair. Then you can also choose a pair for G1 and +B1 and record their colors on the chart above, and an extra wire for +B2, if used. If cable with non twisted pairs is used, just select any four wires (or five if +B2 is used) and record the wire colors here.

STEP 3: Take the meter out of its box by removing 4 screws. Drill a hole in the plastic box in a suitable location to allow the cable to enter the box. The meter circuit board has a 5 pin terminal block on the rear. The five connections are labeled: G1, G2, SIG and +B1 and +B2. Thread the wires or cable through the hole in the box from the outside, and strip insulation off each wire 1/4 inch or so. Use a small screwdriver to loosen the screws on the connector and insert each wire in a separate connector hole using the chart above to determine which wire goes to which terminal, and tighten each screw to hold the wires securely, taking care that there is no danger of shorts between the wires. Install meter in box.

STEP 4: Finally, using the chart above and the wiring drawing on the last page connect the other end of the cable. First connect the G1 and G2 wires to the correct Kelvin terminal on the shunt farthest from the minus battery terminal lead.

(These two wires must join together only *right at* this terminal.) Then connect the SIG wire to the other Kelvin connection, closer to the minus battery connection.

STEP 5: Connect the fuse holder to the battery + terminal, but don't yet put in the fuse. Connect the + wire from the fuse to the TriMetric + terminal. **Then please make a final check of the wiring, and then finally insert the fuse in the fuseholder.** The digits should light up on the meter and battery volts should be displayed.

STEP 6: To check that you've wired the meter and shunt properly: you can do a simple check as follows: **1.** Turn all charging sources and all loads off, with the inverter completely off (not even in "standby"). Be sure that the meter shows very near 0. (0.0 to 0.1 amps.) **2.** Turn on a load and see that it measures correctly. Turning on a 40 W light bulb should cause the "amps" reading to become more negative by about 3 to 4 amps (12V system) or 1.5 to 2 amps, (24V system) plus possibly a little more for the inverter power. **3.** Check charging from each charging source. As you turn each charging source on, (solar, wind, battery charger, etc) be sure that the amps become more positive by about the amount you would expect from that source.

STEP 7: In order to get the "Battery % full" data to read correctly you must enter some programmed data as described in the next section.

C1. Entering required three setpoints in TriMetric memory: First determine correct values to enter, shown just below. Then enter the data as described on page 6 and Table 1 near the bottom. To learn more about what these numbers do refer to USER'S INSTRUCTIONS for TriMetric TM202 Table 2, program numbers P1, P2, P3. The volts, amps and watts will read correctly on the meter even if you do not set these values correctly. "Battery % full", "Amp hours from full" and "Days since charged" displays will NOT be correct until you properly enter the first three values. This section will help you to determine what those numbers should be. Beyond this there are three additional ones that are useful, but are of lesser importance—covered after the first three.

The meter comes factory set to Operating Level L1, which is the simplest level of operation. **The brief instructions in the section only relate to level L1.** It is advisable to begin with this which is suitable for most applications—it is easy to change it later (to levels L2 or L3) if after reading the instructions more flexibility, or a higher level of operation is desired. It may be changed at any time by program P7 (see Table 1 on page 7).

As you determine the following three numbers, write them in column 3 of Table 1 page 7. Then program them in the TriMetric as described page 6, near Table 1.

What's the purpose of these numbers? The numbers P1 and P2 tell the meter when your batteries have been charged: that is, when the battery 1 voltage goes ABOVE P1, and the charging amps go BELOW P2. Then the meter will reset the "% Full" to 100%, the "amps hours" to 00.0 and your "Days since charged" to zero. P3 calibrates the "Battery% full" display according to your battery size.

How to determine value for program item P1: the "charged setpoint voltage"

If you understand the following sentence, then do the following: Determine the "absorption charging voltage" to which your charger or charge controller limits the charging voltage. The "charged setpoint voltage" for the TM-2025 should be set 1% to 2% below this "absorption charging voltage". For a 12 volt system can be taken as 0.1-0.2 volts less than the "absorption charging voltage" setting. For a 24V system 0.2-4 volts less.

If you don't know what this means: Then start with the following: If you have liquid electrolyte batteries (those with watering caps on top) use **14.3** volts for 12 volt systems, or **28.6** volts for 24 volt systems. For Gel or AGM type batteries for 12V systems use **14.0**. However, since probably one reason you bought this meter was to better care for your batteries, we highly recommend at some point reading: **Important information about battery charging to keep from killing your batteries in section 7 of the USER'S INSTRUCTIONS for TriMetric TM2025.**

Record value in the space provided for the first item of Table 1, column 3 page 7.

How to determine value for program item P3: "battery system capacity" amp hours. This is a number in "amp hours" which describes how much charge (or energy) your batteries hold when they are fully charged. For "deep cycle" batteries this number is specified by the battery manufacturer. If you have only one battery then use that value. It is more usual to have more than one battery connected in series or parallel. In this case the rule is that when you put identical type batteries in series the amp hour of the series string is the same as the amp hour rating of any one of batteries in the string. When you put them in parallel then you add the amp hours of each battery. When you have batteries that are both in series and in parallel, then compute the amp hour of EACH series string. Then multiply the amp-hours of each series string by the number of strings in parallel to get the total value of amp hours. Put this value in the "battery system capacity" (P3) in Table 1 on page 7. **Note that when the decimal point flashes, that means "multiply the display value by 1000".**

How to determine value for program item P2: “charged setpoint amps” Just take the value you found for P3 above and multiply it by 2, then divide the result by 100—to give a value in amperes. Put this value in “charged setpoint amps” (P2) in Table 1.

Now that you have these three values program them into the TriMetric as described at the bottom of page 6. The meter should then be set up to properly measure volts, amps, watts, battery %full, amp-hours from full and days since charged.

C2: Information on the next (optional) three program setpoints: P4, P5 and P6. Do these if you like.

Selecting value for P4: Do you prefer to read “watts” or “amps”? This meter allows you to see the flow of energy in or out of the battery by either observing the AMPS or WATTS. Here is how they are related:

$$\text{Watts} = \text{Amps} \times \text{system volts}$$

When originally received, the AMPS reading is among the **primary** display items, and the WATTS show on the **secondary** display items. If desired, you may switch the order, so that the WATTS show as a primary item, the AMPS show as the secondary item. This is done by the P4 program item described below in Table 1. A small label that says “Watts” is supplied [**will soon be available**] with this meter that may be used to place over the “Amps” nomenclature on the panel if this is desired.

If you are used to thinking in “amps” you may prefer that as your primary display. One advantage of “watts” is that if you are using an inverter to power 120V appliances, the watts display shows you the actual watts to power them. So a 15 watt light bulb should show as a draw of about 15 watts (or actually a little more since your inverter/converter is not 100% efficient in its power conversion). Many people find “watts” to be more familiar.

Selecting a value for P5: “Battery recharge reminder”: Lead acid batteries should be periodically fully charged for maximum life—and also for the meter to maintain a more accurate “% Full” display. The default P5 value is programmed as “OFF”—but if you would like to be reminded to fully charge them after they have NOT been charged for several days you can use this to remind you. If you set it to our recommended value of “5”, then after five days of not reaching their charged state (according to the values you programmed in P1 and P2 above) the meter will flash an occasional “Ch F” in the display (when the primary displays are being shown.) This should signal you to charge your batteries to get fully charged. When the batteries are charged the “Charging” lamp will start flashing, and the “Ch.F” in the display will cease flashing.

Selecting a value for P6: “Battery equalizing reminder”: The default setting is “OFF”. For batteries which need periodic equalization, this can be used to remind you when to perform this operation, which is usually recommended for “liquid electrolyte batteries” (but often not the gel or AGM types.) Some chargers perform this automatically, but if yours requires manual intervention than you may use this to remind yourself to perform this task. You can set in the interval in days that you wish to elapse between equalizations. Then it will flash “Ch E” periodically after that number of days has elapsed to remind you to equalize. **After you have performed the equalization process you will need to MANUALLY RESET the “days since equalization” display by going to this display** and holding the “RESET” button for several seconds, until the number in the display goes permanently to ‘0’. It does not do this automatically. See section 7 of the **USER’S INSTRUCTIONS for TriMetric TM2025** for more information on equalization.

Programming instructions: Also see Table 1 to right, on page 7

To **observe** data follow steps 1 and 2. To **change** data follow additional steps 3 and 4.

- (1) HOLD DOWN the SELECT button and watch as the display cycles through several different displays. When you see **P1** in the display, immediately release SELECT. If you don’t release quickly enough, just wait longer holding down SELECT until you see the **P1** again, then release. Then the programmable data shown in column 2 for P1 (in Table 1) will alternate with “**P1**”, so you can observe its value.
- (2) Push SELECT repeatedly to observe programmed data P2, P3, etc, as shown in the left two columns in Table 1. After going through all these it will go back to observing normal display data. (Volts, Amps, etc.)
- (3) If during step 2 you see data that you wish to CHANGE, push **SELECT and RESET firmly at the same time**. Three green lamps will flash to indicate that you are in the CHANGE mode. Then giving successive pushes to RESET will increase the numbers slowly. Holding RESET down a little longer will speed up the change—and will cause data to cycle more quickly through all the possibilities. To make values go down, you will need to keep increasing until it finally jumps to its lowest value again.
- (4) When satisfied with the data, push SELECT to get out of the CHANGE mode and back into OBSERVE mode. Now continue again as described in step 2.

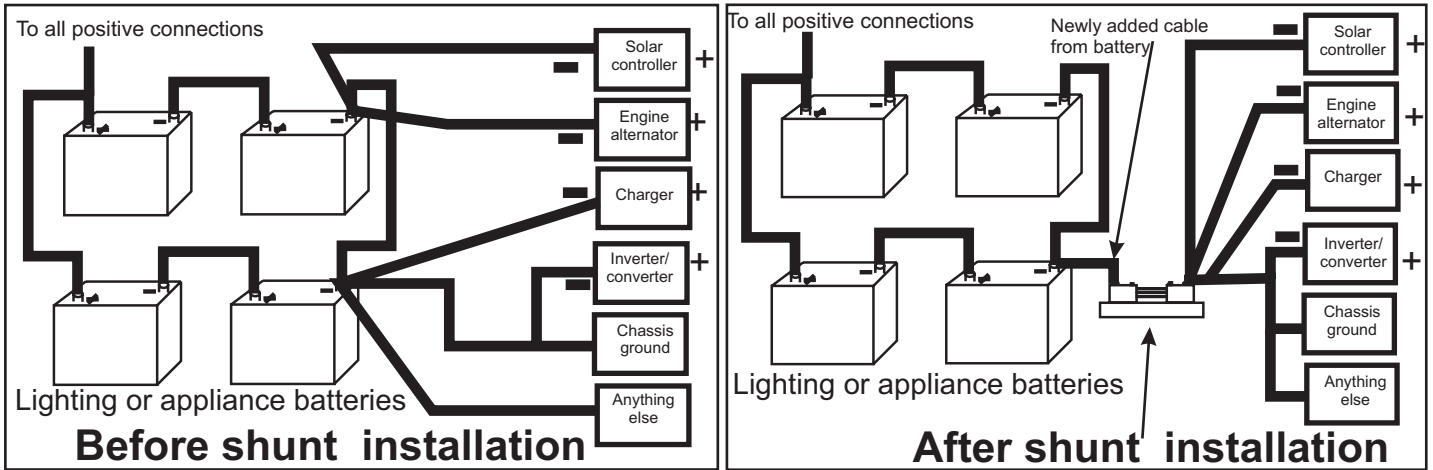

The above drawing will not show your exact situation--this example is unusually complicated. It is intended to show that you need to first remove every cable or wire that goes to the negative connection on your battery system before installing the shunt. All of these will need to be reconnected to the right side of the shunt as shown in the right drawing.

The shunt may be installed either way. It does not have a polarity.

In the diagram above the left side of the shunt should be connected only to the negative side of battery or battery set.

Note that in that drawing all the current from and to the negative terminal of the battery (system) flows through the shunt. This is necessary for the meter to measure the battery "amps" properly and also for the "Battery % full" display on your meter to work. Of course this does not mean that your connections on the right side of the shunt will be precisely as shown.

Figure 1: Where to install shunt

PROGRAM MODE NUMBER	PROGRAMMABLE DATA and ADJUSTMENT RANGE SEE INSTRUCTIONS TO LEFT (ON PAGE 6)	Factory value
		Your value
P1	"CHARGED" setpoint voltage: 10.0 to 65.0V	28.6
P2	"CHARGED" setpoint amps: 1 to 100 Amps	OFF
P3	"Battery Capacity" Amp-hours: 10 to 9,990 amp hours NOTE: Flashing decimal point means "multiply number by 1000"	400
P4	"watts" or "amps" choice: Pr =watts A =amps	A
P5	Days before "time to recharge" reminder: 1 to 100 days or OFF	OFF
P6	Days before "time to equalize" reminder: 1 to 100 days or OFF	OFF
P7	Choose OPERATION LEVEL: L1 , L2 or L3 .	L1

Table 1

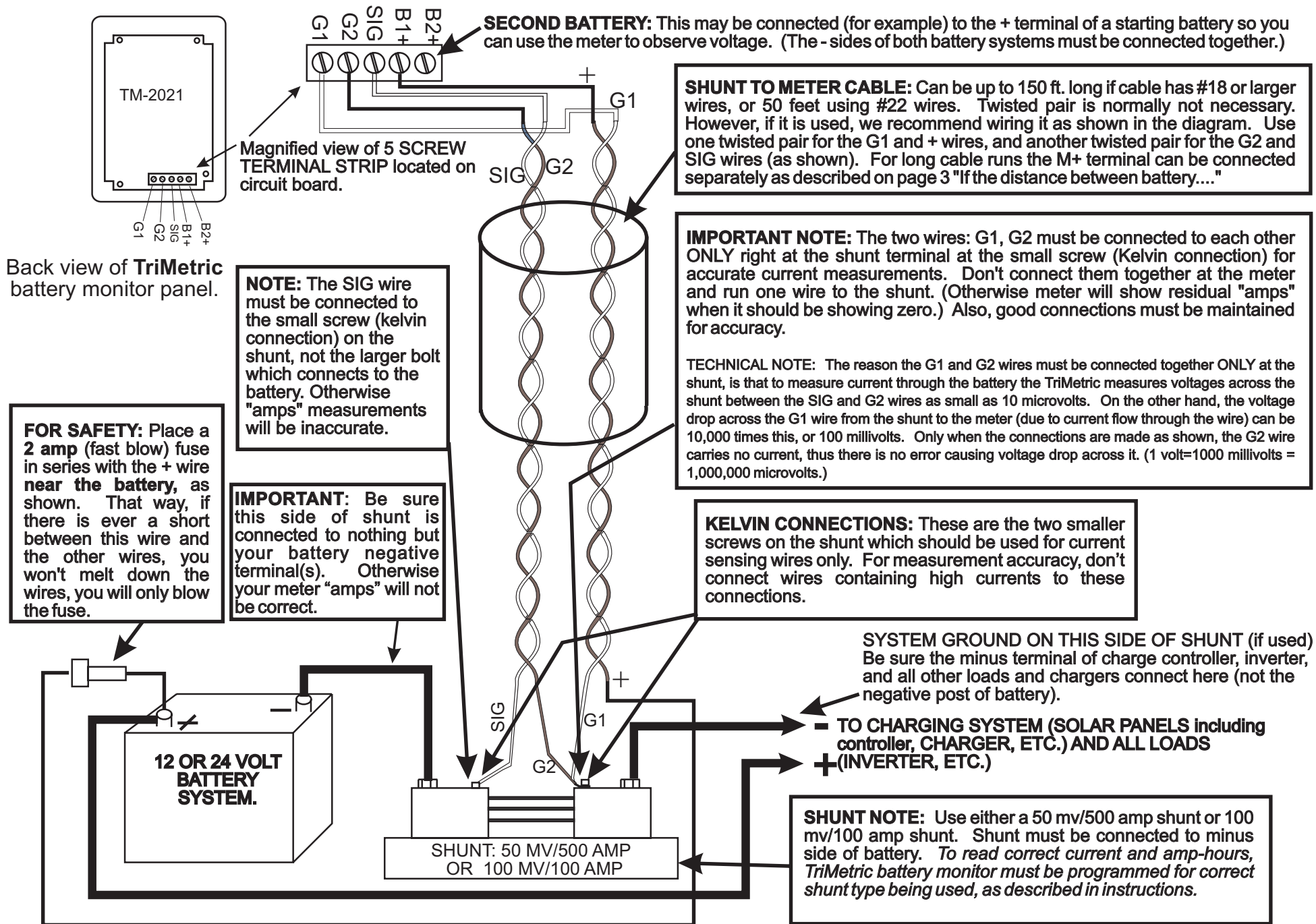

FIGURE 2: TM-2025 TriMetric BATTERY MONITOR CONNECTIONS. Please read all notes carefully. (Technical notes optional.)